



# Installation and Operating Instructions

## Hand rail bracket, 62mm



Hand rail bracket, 62mm

111703

Available colours: WHITE (WH). ZINK (ZI).

Congratulations on the purchase of your NYMAS product. This product has been designed for use with a timber hand rail.

### Warnings:

- Always read the installation, operating and maintenance instructions.
- Due to manufacturing tolerances we do not recommend pre-drilling fixing holes before physically receiving this product.
- A thorough check must be carried out on receiving delivery of this product and report any defects immediately.
- Opening the packaging without due care and attention could result in damage to the product or injury to yourself or others.
- This product must be stored in a dry place, the right way up and not stacked under other equipment on site.
- The substrate on which the product is installed must be flat and capable of taking the load.
- We cannot guarantee that this product is completely ligature free and must be subjected to a risk assessment per installation.
- Installation must be carried out by a qualified tradesman using suitable fixings for the wall substrate.
- Never alter the fixing holes as this could affect the strength and integrity of the rail.
- Improper installation / use can cause accidents and injuries.
- This rail should not be installed in wet or humid environments as this may result in rust issues.
- Beware after installation a functional test must be carried out prior to use.
- Beware these instructions should be retained by the user of the product for its whole life time.
- Do not use the rail for any purpose other than that for which it was designed.
- Do not use the rail if damaged / not securely fixed as this may cause injury.
- Keep plastic bag packaging away from children.
- Beware the rail should not be subjected to impact.
- Beware to maintain the integrity and functionality of this product, regular cleaning and inspection is necessary.
- If in doubt, carry out your own risk assessment per installation.



# Installation and Operating Instructions

## Installation:

Installation should be carried out by a suitably qualified tradesman using correct fixings for the substrate. Fixings are not supplied with this product to allow the correct fixing method to be selected per installation. Consult a fixing manufacturer if unsure of which type of fixings to use.

1. Once the correct fixing type has been selected, 3 x 5mm diameter fixings should be employed in each fixing disk.
2. Offer the post up to the position required.
3. Mark the fixing hole locations.
4. Drill the holes in the substrate of a diameter and depth recommended by supplier of the fixings.
5. Fix the rodcut in the desired location.
6. Use 2 x 5mm fixings to attach the timber hand rail (not supplied) to the bracket.
7. Always carry out a functional test after installation and report any issues immediately.
8. Please leave these instructions with the user.

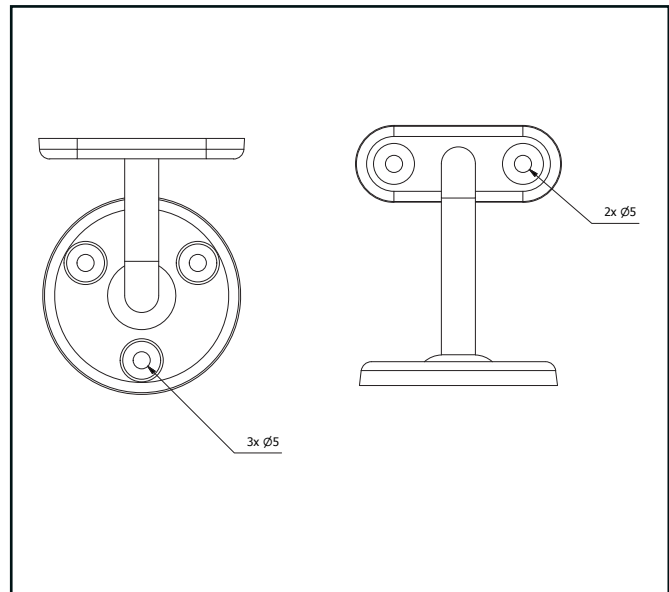

---

## Using this product:

Always check this product is fitted securely to the substrate and shows no signs of wear or damage prior to use. Please keep these instructions in a safe place for future use. These instructions are available in braille if required.

---

## Cleaning and maintenance:

This product must be checked regularly by a qualified personnel to ensure that it is in perfect working order. This product can be cleaned using only a very mild detergent. Do not use acidic, alkaline, chlorine based or abrasive cleaning materials.

---

## Packaging:

This product is supplied in plastic wrapping and cardboard carton to keep the product unsoiled until installation. Both are suitable for recycling operations and should be disposed of in accordance with local recycling regulations.

---

## Warranty:

The standard of manufacture and quality control allows Nymas to offer warranties on all products. The standard 1 year warranty applies to this product. (Terms and conditions apply).

---

## Disclaimer:

Nymas pursues a policy of continuing improvement in design and performance of its products and so reserves the right to change specifications without prior notice. The information contained on this document was correct at date of issue and dimensions are provided as a guide only. Some variation may occur due to manufacturing tolerances.

We accept no liability whatsoever for personal injury or damage to property that is or has been caused due to incorrect assembly, installation, or use of this product. Failure to install / use this product in line with these instructions will invalidate any warranty and may affect product safety.